

28GHz n257 5G Surface Mount Bandpass Filter

B280MF1S

DESCRIPTION

One of DLI's surface mountable catalog bandpass filters designed for the n257 5G band. This filter utilizes DLI's low loss temperature stable materials which offer small size and minimal performance variation over temperature.

FEATURES

- Small Size
- Shielded
- Surface Mount
- Moisture Sensitivity Level: MSL1
- Frequency Stable over Temperature
- Operating & Storage Temp: -55°C to +125°C

Packaging and Ordering information:

To request tape and reel packaging, please order part number **B280MF1S-T**

SPECIFICATIONS*

Parameter	Frequency Range (GHz)	Min*	Typ.	Max*
Insertion Loss (dB)	26.5 - 29.5	—	1.8	2.9
Return Loss (dB)		10	16	—
Low Side Rejection (dB)	DC - 24.5	20	23	—
	24.5 - 25.5	10	12	—
High Side Rejection (dB)	30.7 - 31.3	10	12	—
	31.3 - 42.0	20	25	—
Size (L x W x H)	4.0 x 2.3 x 1.8 mm			

*Electrical specifications based on typical probed performance at room temperature. Insertion loss shall vary up to ±0.5 dB over temperature.

Typical Measured Data

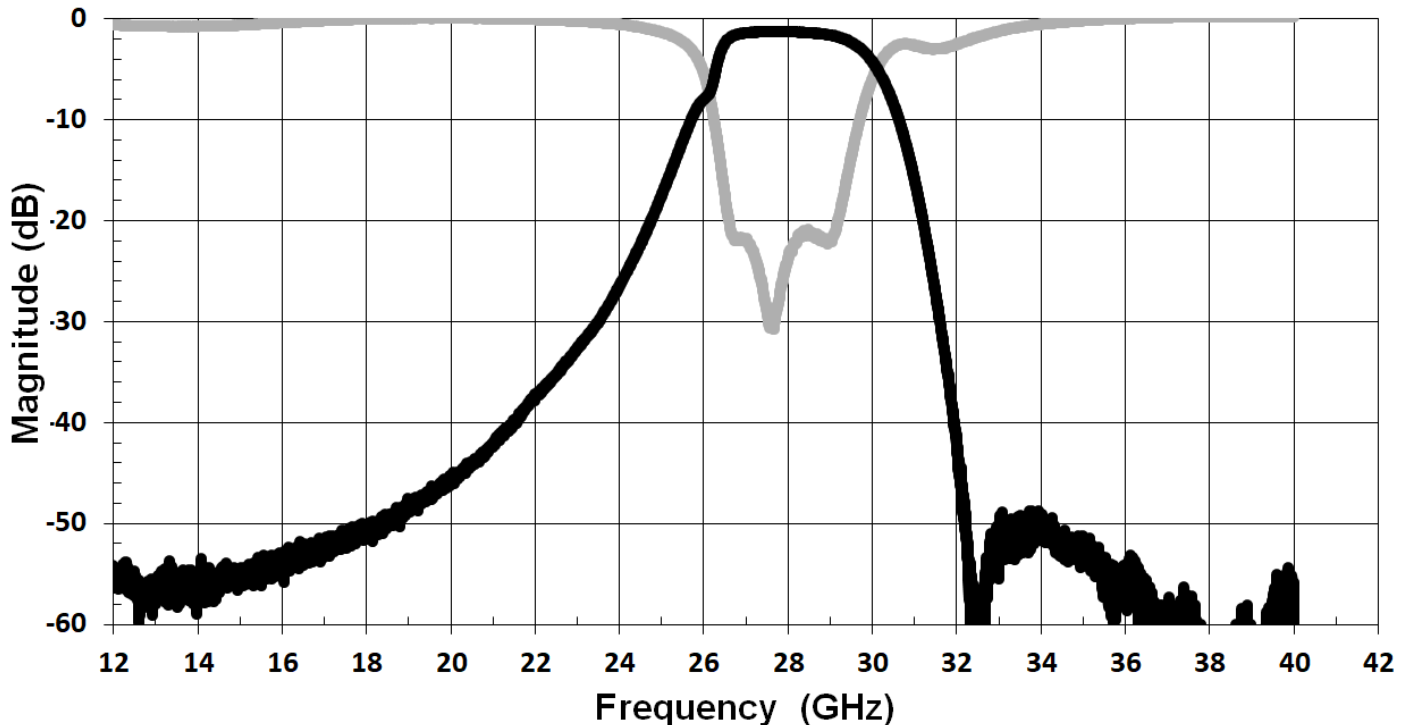

28GHz n257 5G Surface Mount Bandpass Filter

B280MF1S

Physical Dimensions

Units = inches (in)

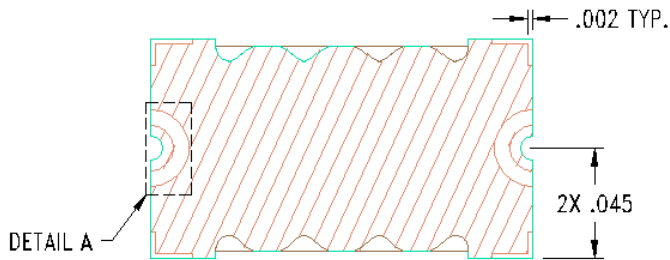
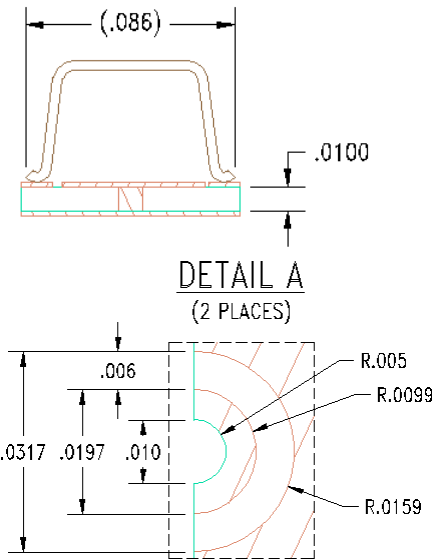
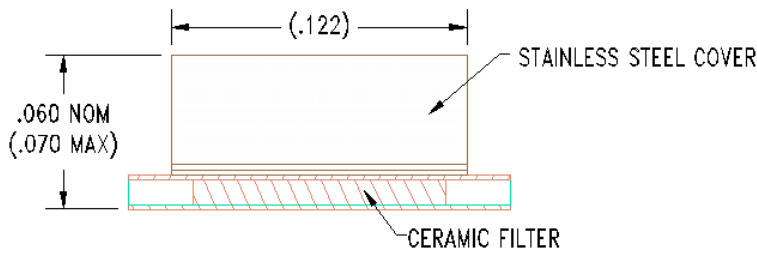
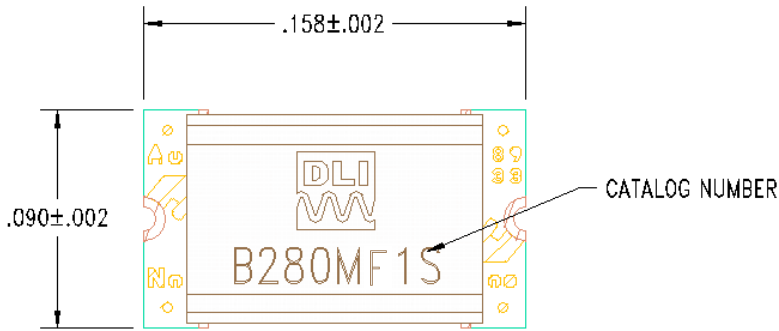

Recommended PCB

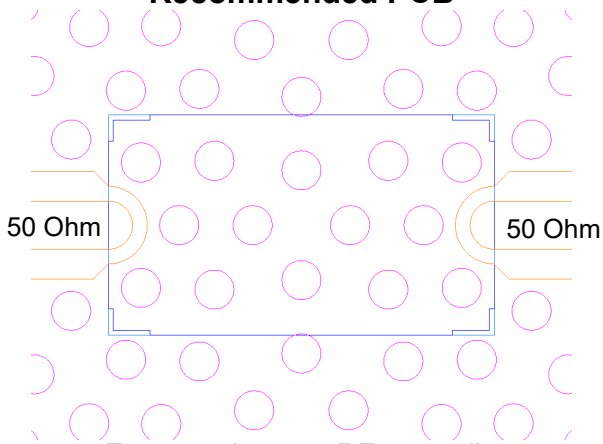

Recommended Solder Paste Pattern

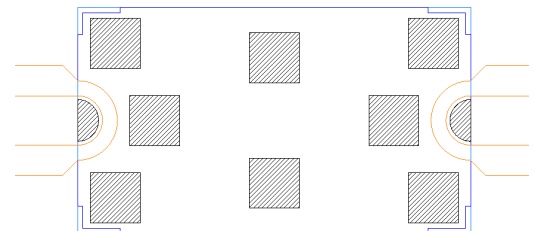

- Ensure adequate RF grounding

